



HALCO PRODUCTS COMPANY

100 N. Gordon Street - Elk Grove Village, IL 60007-1193

Tel: 847-956-1600 - Fax: 847-956-0595

E-Mail: Info@Halco-Products.com

Website: www.Halco-Products.com

HALCO
PRODUCT
INFORMATION

500.1000

ECONOMY TABLETOP SERIES

EXCLUSIVE FEATURES:

- High density particle board construction (more weight-less noise-less vibration)
- Exposed surfaces covered with Formica (or equal)
- Motor / Blower Speed Control
- Stainless steel polished work surface*
- Comfort edge soft neoprene saves elbows and garment sleeve
- Duplex convenience outlet *
- Static Pressure Gauge
- Traverse fluorescent fixture *
- Ultra-violet lamp *

* Optional at additional cost



SPECIFICATIONS:

FILTERS: Prefilters — disposable filters change in one minute. HEPA filter efficiency 99.99% in removing all particles 0.3 micron or larger. Removable front protection grill for easy service or testing of HEPA filter. HEPA filter is integral part of plenum —no seals to leak and no leaks to seal —100% integrity. (Cost of replacing Filter/Plenum is less expensive than Filter replacement service and certification). Ask us to prove it. Life expectancy of HEPA filters under normal conditions 8,000 to 12,000 hours.

AIR FLOW: Sterile air produced across the work area meets requirements of Class 100 (Federal Standard 209E), bio.-clean conditions. Adjustable voltage regulator maintains a nominal 100 FPM air velocity.

BLOWER: Dynamically balanced with special vibration and noise arrestors. Rubber shock mounted with flexible duct to take up resonance vibration.

MOTOR: Permanently lubricated, requires no maintenance.

WIRING: Meets all electrical codes. Operates on 115 volts, 15 amps.

CONSTRUCTION: Novoply with pressure bonded Melamime laminate (Formica or equal) on external surfaces —Table Top 1½” thick with “comfort edge” (see legend) and covered with polished Stainless Steel.*

OPTIONAL ACCESSORIES: Rod for hanging solution bottles; service valves for gas, air, vacuum; faucets, sink and drain; ultra violet light, duplex electrical outlet.

SPECIFICATIONS

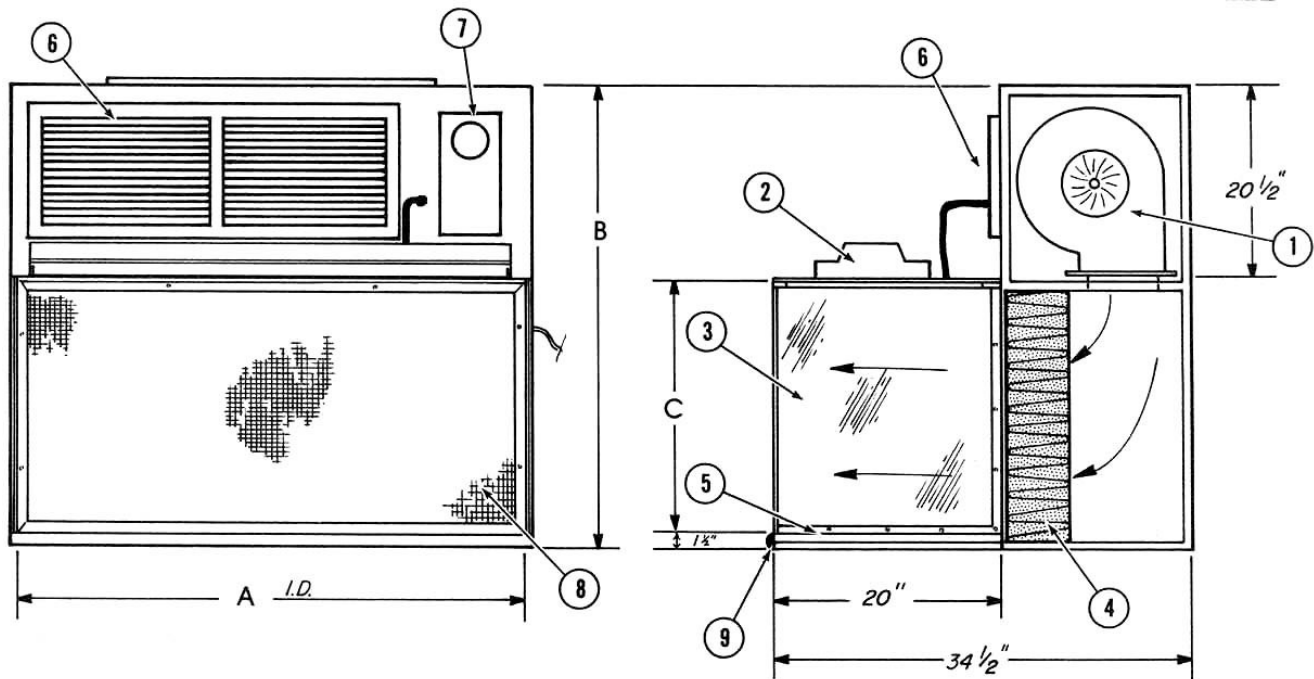

CERTIFICATION:

Each work station is certified (Federal Standard 209E) to meet Class 100 requirements

GUARANTEE

Fully guaranteed against defective workmanship or material. A written guarantee accompanies each unit. Halco offers a system that is unconditionally guaranteed for one full year from delivery.

TYPICAL COMPONENTS

1. Shock-mounted direct drive blower
2. Transverse light fixture
3. Plexiglass enclosure
4. HEPA filter
5. Worktable
6. Air inlet grill and disposable prefilter
7. Control panel
8. Anodized aluminum protective grill, removable
9. Comfort edge

Nominal Dimensions							
Model No.	A.	B.	C.	Model No.	A	B.	C.
EL322TT	38"	46"	23½"	EL522TT	62"	46"	23½"
EL3302TT	38"	52"	29½"	EL5302TT	62"	52"	29½"
EL422TT	49"	46"	23½"	EL62TT	74"	46"	23½"
EL4302TT	49"	52"	29½"	EL6302TT	74"	52"	29½"

HALCO PRODUCTS COMPANY

100 North Gordon Street
 Elk Grove Village, Illinois 60007-1193
 (847) 956-1600 Fax (847) 956-0595
 E-Mail: Info@Halco-Products.com
 Website: www.Halco-Products.com

In line with our policy of continual product improvement, HALCO reserves the right to incorporate and use equipment and material to conform with the latest design of its products, and in keeping with the specifications of this equipment.