

| REVISIONS | | | |
|-----------|-------------|------|----------|
| REV | DESCRIPTION | DATE | APPROVED |
| | | | |

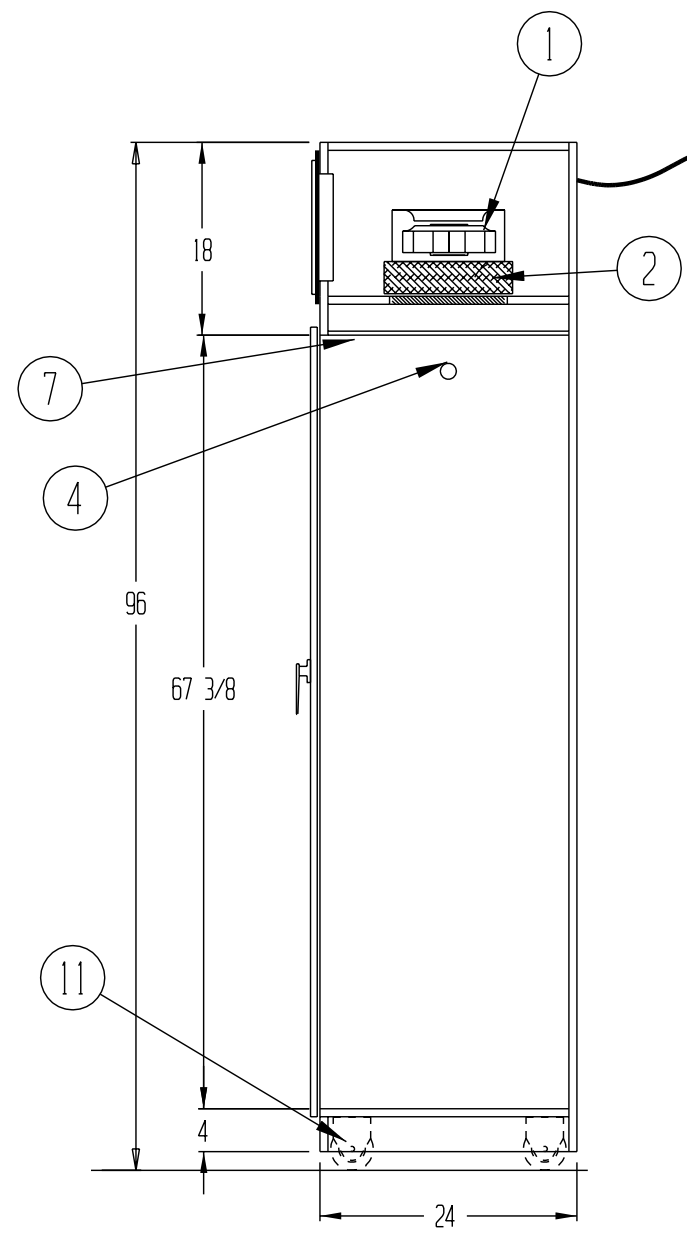
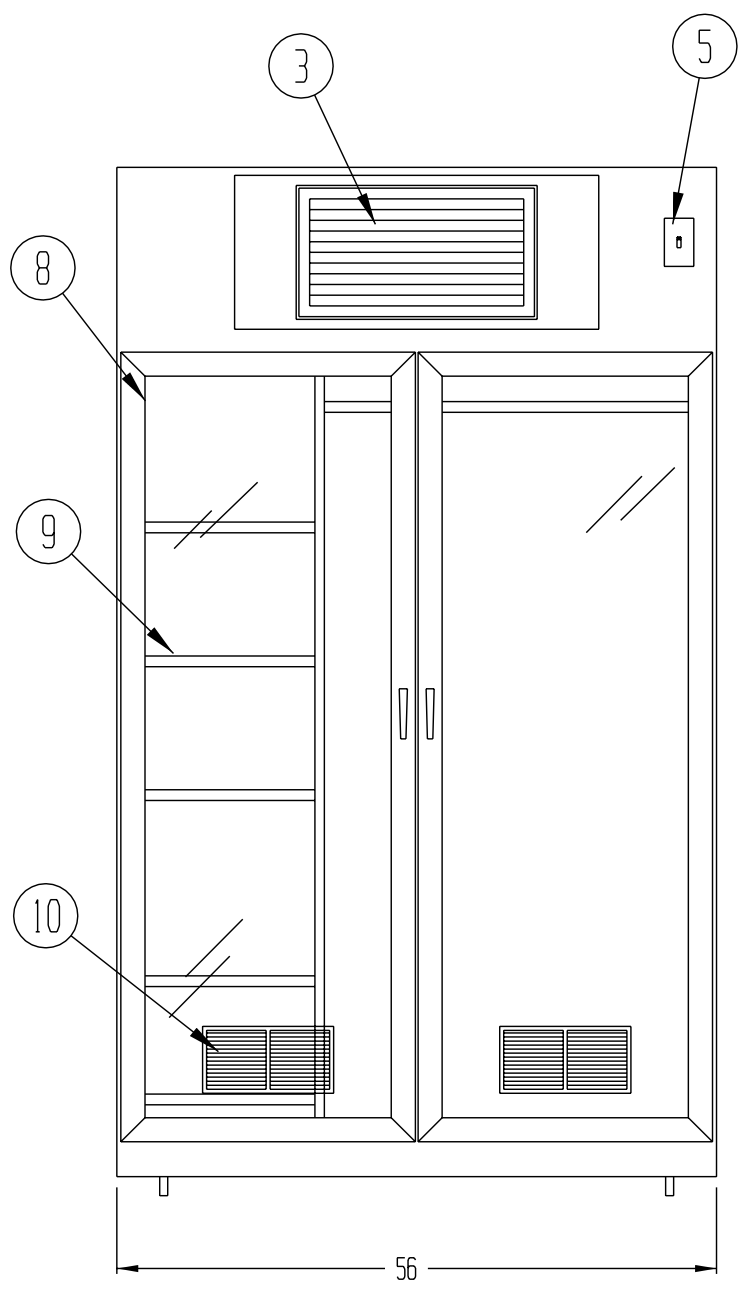

- ① FTE1224 FAN POWERED UNIT 115 VOLT/
1 PHASE/60 CYCLE/3.0 FLA.
- ② 1 EA. 12 X 24 X 4 1/4" ANODIZED ALUMINUM FRAMED
HEPA FILTER. 99.99% EFFECTIVE ON PARTICLES OF
0.3 MICRONS AND LARGER.
- ③ 1 EA. 20 X 10 X 1" ANODIZED ALUMINUM PRE-FILTER
GRILL WITH A 35% EFFICIENT DISPOSABLE PRE-FILTER.
MOUNTED IN ACCES PANEL
- ④ ALUMINUM HANGING ROD
- ⑤ POWER SWITCH
- ⑥ 9' ELECTRICAL CORD WITH PLUG
- ⑦ ANODIZED ALUMINUM PROTECTIVE HEPA GRILL
- ⑧ ANODIZED ALUMINUM FRAMED DOORS WITH 1/4" THK.
ACRYLIC GLAZING.
- ⑨ ADJUSTABLE PERFORATED STAINLESS STEEL SHELVES
- ⑩ (2) ANODIZED ALUMINUM VENT GRILLS
- ⑪ (4) SWIVEL CASTERS

NOTES:

- UNIT TO BE CONSTRUCTED OF 3/4" THK. HIGH DENSITY PARTICLE BOARD
- INTERIOR OF STORAGE COMPARTMENT AND ALL EXTERIOR SURFACES
TO BE COVERED WITH WHITE HIGH PRESSURE PLASTIC LAMINATE
- ALL OTHER SURFACES TO BE COVERED WITH NON-SHEDDING VINYL
- ELECTRICAL TO MEET LATEST NEC CODES
- UNIT TO MEET ISO STANDARD 14644-1

| | | | | | |
|-------------|-----|--|------------------|-------------------|-------|
| DRAWN FOR | | HALCO PRODUCTS CO. | | | |
| | | 100 NO. GORDON STREET ELK GROVE, IL. 60007 | | | |
| | | TITLE GL56HH/HB/SP | | | |
| DRAWN BY | SLB | SIZE | JOB NO. 10402 | DWG NO. 1611841B0 | REV |
| APPROVED BY | -- | SCALE | 1 1/4" = 1' - 0" | DATE 4/9/02 | SHEET |