

| REVISIONS | | | |
|-----------|-------------|------|----------|
| REV | DESCRIPTION | DATE | APPROVED |
| | | | |

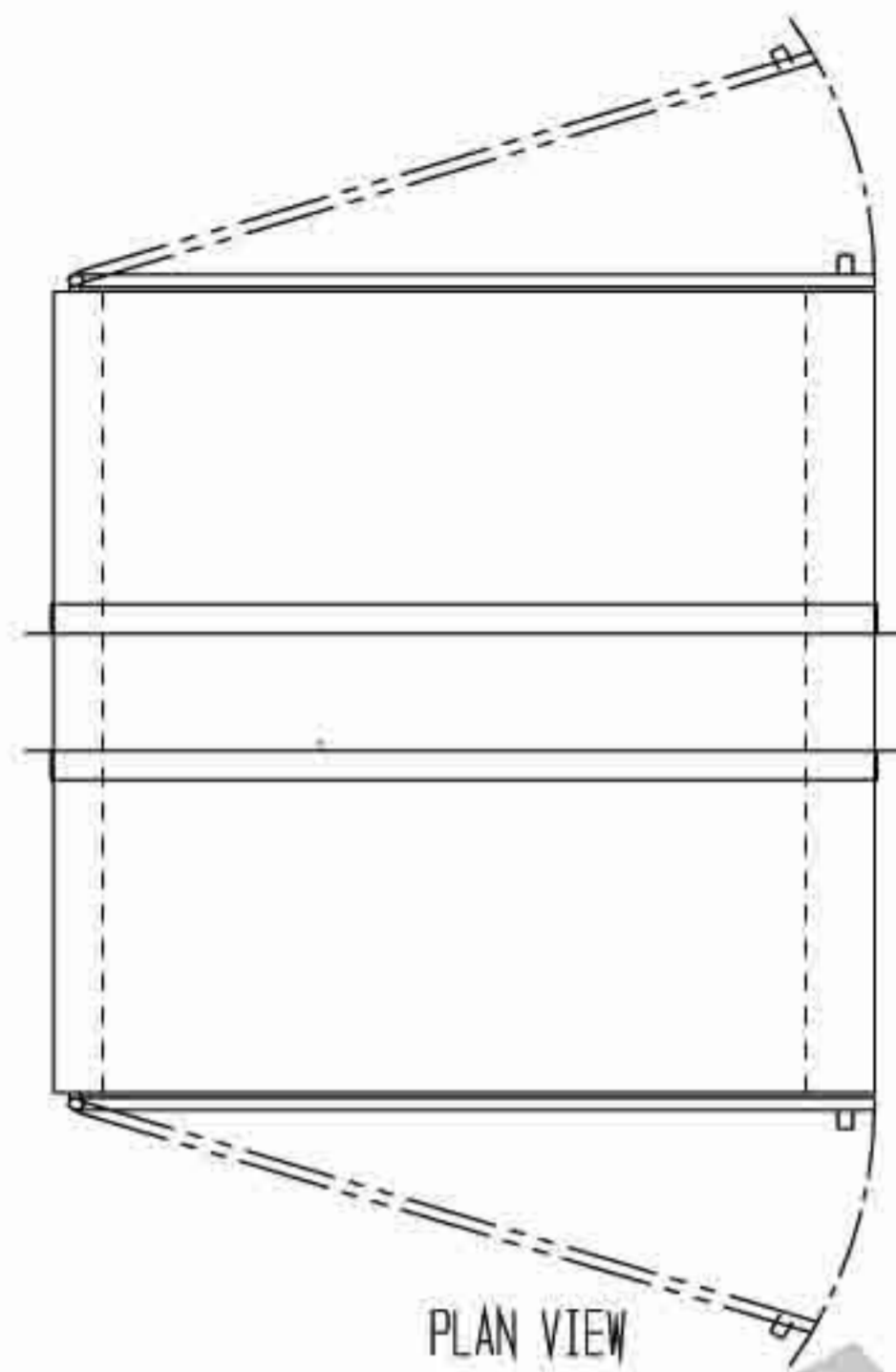

PLAN VIEW

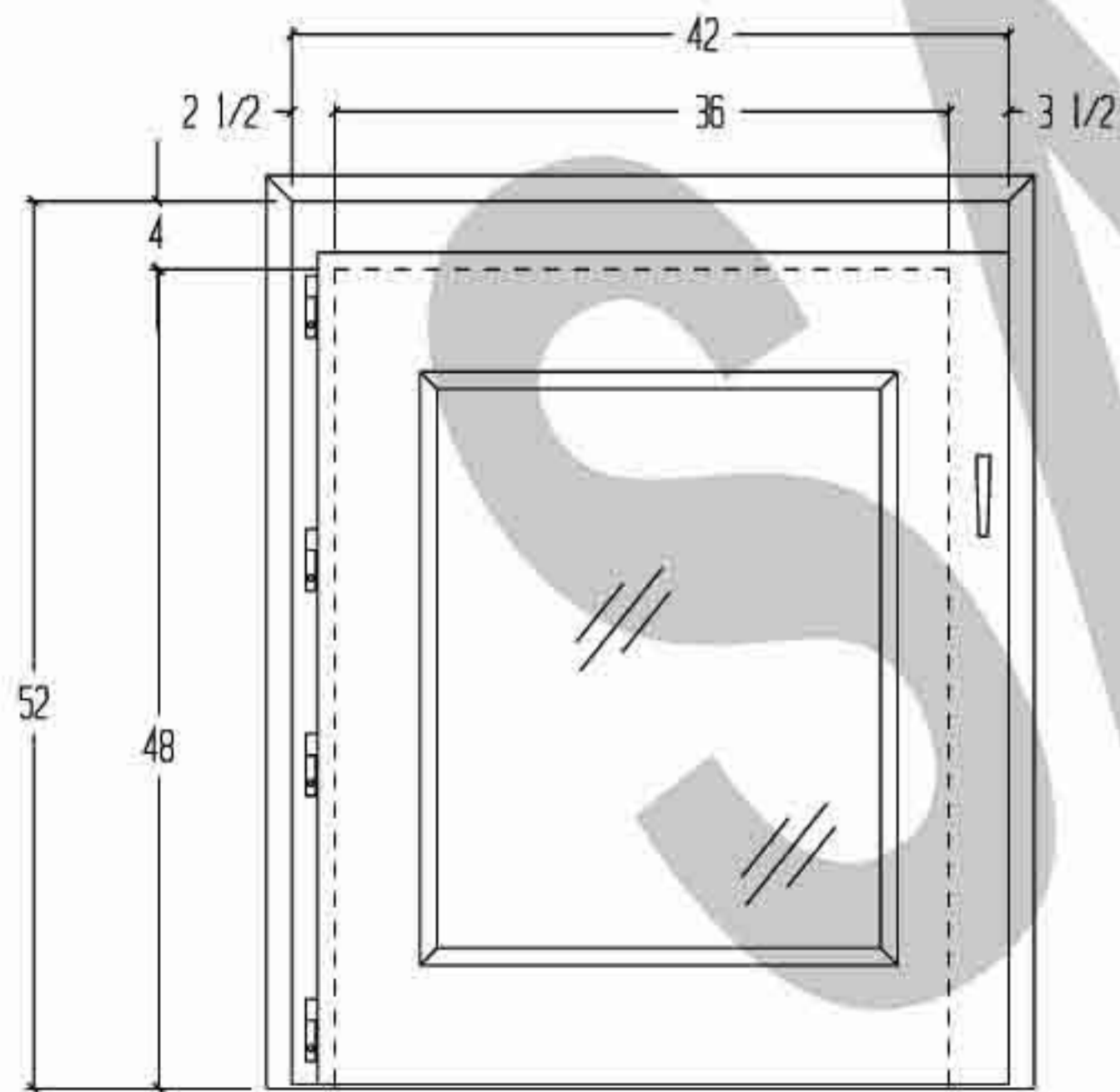

FRONT VIEW

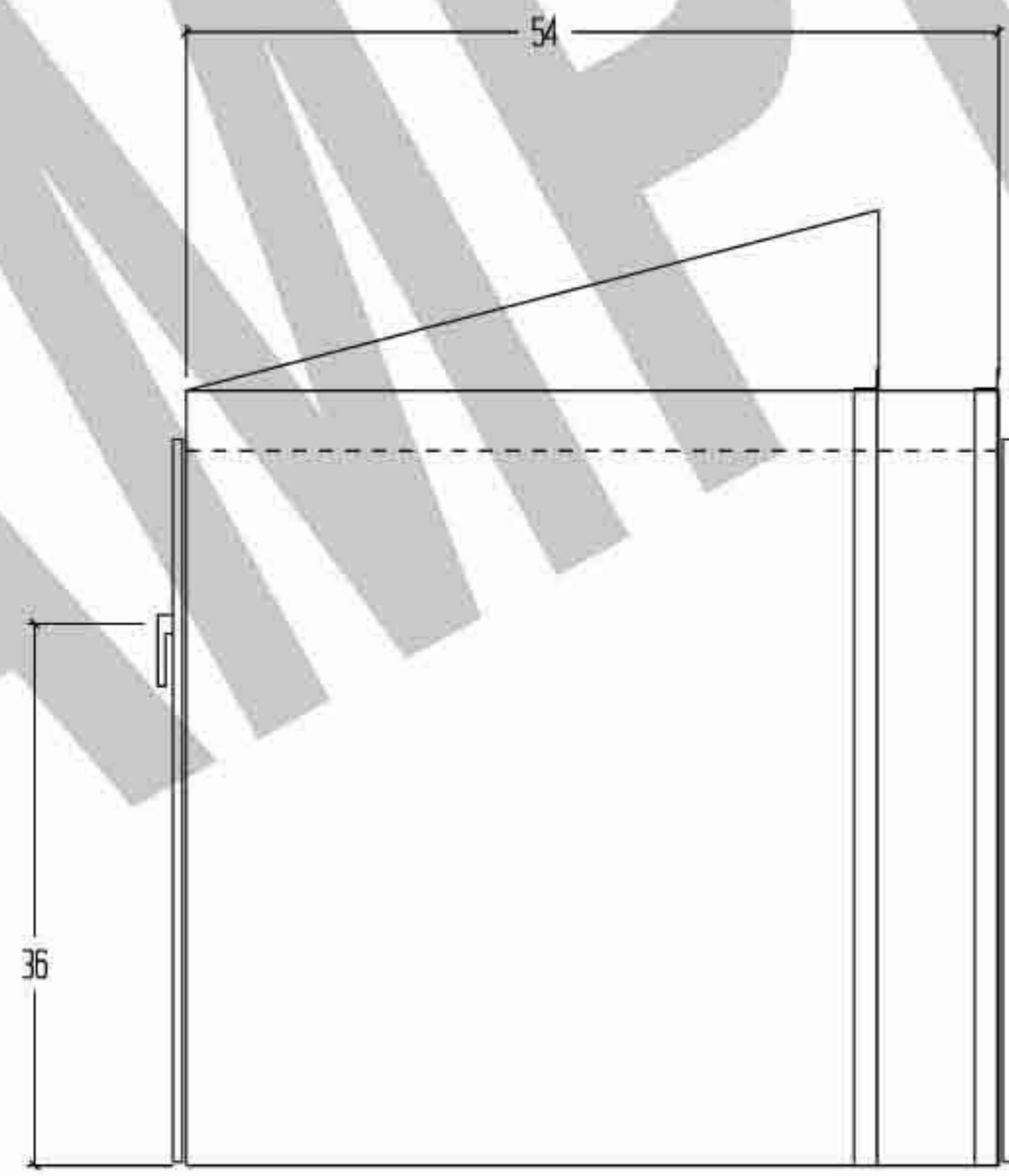

SIDE VIEW

NOTES:

- UNIT FABRICATION TO BE DOUBLE WALL, CONSTRUCTION
- UNIT TO BE CONSTRUCTED OF 16 GA. 304 STAINLESS STEEL WITH #4 FINISH.
- DOORS TO BE CONSTRUCTED OF 20 GA. 304 STAINLESS STEEL WITH 1/4" THK. ACRYLIC WINDOWS, BULLET HINGE, QUARTER TURN HANDLES
- UNIT TO BE SUPPLIED 16 GA. 304 STAINLESS STEEL ANGLES TO ATTACH INTERIOR SIDEWALLS TO FLOOR
- UNIT TO BE SUPPLIED WITH 1 1/2" X 1 1/2" X 16 GA. 304 STAINLESS STEEL MOUNTING ANGLE (TO BE FIELD TRIMMED & INSTALLED)
- UNIT TO HAVE A MECHANICAL DOOR INTERLOCK SYSTEM
- ROUGH OPENING TO BE 1/4" LARGER THAN OUTSIDE DIMENSIONS OF UNIT
- UNIT SUPPLIED W/ SLOPPED TOP, DIMENSIONS TO BE FIELD MEASURED

(2) UNIT REQUIRED, AS SHOWN

| | | | | | |
|-------------|----|--|------------|---------|---------------|
| DRAWN FOR | | HALCO PRODUCTS CO. | | | |
| | | 100 NO. GORDON STREET ELK GROVE, IL. 60007 | | | |
| | | TITLE CPT3648-54 SS/MI | | | |
| DRAWN BY | TM | SIZE | JOB NO. | DWG NO. | REV |
| APPROVED BY | | SCALE | 3/4"=1'-0" | DATE | 1-17-05 SHEET |