

REVISIONS			
REV	DESCRIPTION	DATE	APPROVED

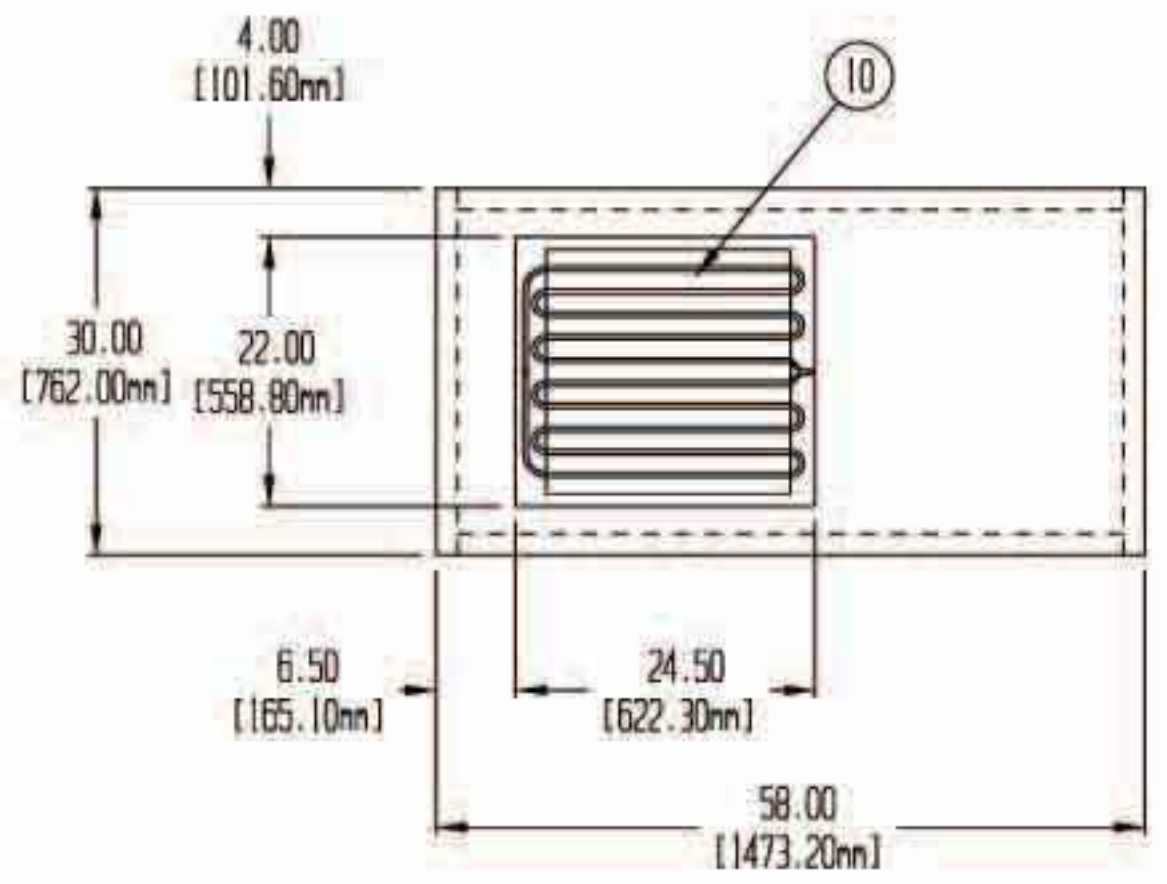

CONSTRUCTION:

- FILTER MODULE TO BE CONSTRUCTED OF 16 GA. GALVANNEALED STEEL COATED WITH WHITE EPOXY PAINT
- FRAME AND TABLE BASE TO BE CONSTRUCTED OF 1 3/4 X 1 3/4 X 14 GA. SQUARE TUBULAR STEEL PAINTED WHITE EPOXY PAINT
- TABLE TOP TO BE 16 GA. TYPE 304 STAINLESS STEEL
- UNIT TO MEET OR EXCEED FEDERAL STANDARDS 209B & 209E FOR CLASS 100 DEVICES
- ELECTRICAL WIRING TO CONFORM TO LATEST NEC STANDARDS

- ① 1 EA. 9-GAT DIRECT DRIVE BLOWER WITH 1/3 HP HIGH EFF. MOTOR. CAPABLE OF PRODUCING 1000 CFM @ .75" S.P.
- ② 1 EA. 24 X 60 X 3" ANODIZED ALUMINUM FRAMED HEPA FILTER. 99.99% EFFECTIVE ON PARTICLES OF 0.3 MICRONS IN SIZE
- ③ 2 EA. 12 X 24 X 1" 35% EFFICIENT PRE-FILTERS WITH FLUSH MOUNTED STAINLESS STEEL GRILLS
- ④ RECESSED CONTROL PANEL WITH MOTOR DISCONNECT/SPEED CONTROL, LIGHT SWITCH AND MANHETIC PRESSURE GAUGE
- ⑤ ELECTRICAL JUNCTION BOX FOR CUSTOMER CONNECTION. 220/1/50 HZ. 4.4 FLA
- ⑥ 2 EA. F60T12CW FLUORESCENT LIGHTS. CAPABLE OF PRODUCING 100 F.C. AT THE WORK SURFACE
- ⑦ EPOXY PAINTED TUBULAR SUPPORT FRAME WITH SOLID REAR PANEL AND 1/4" CLEAR POLYCARBONATE SIDE PANELS
- ⑧ ADJUSTABLE LEG LEVELERS ON SUPPORT FRAME AND TABLE
- ⑨ CLEAR POLYCARBONATE FRONT SHIELD WITH COUNTER BALANCE SYSTEM
- ⑩ 20 X 20 WORK SURFACE WARMING PLATE
- ⑪ 1 EA. 2KW RECIRCULATING HEAT PUMP WITH SEPERATE POWER CONNECTION

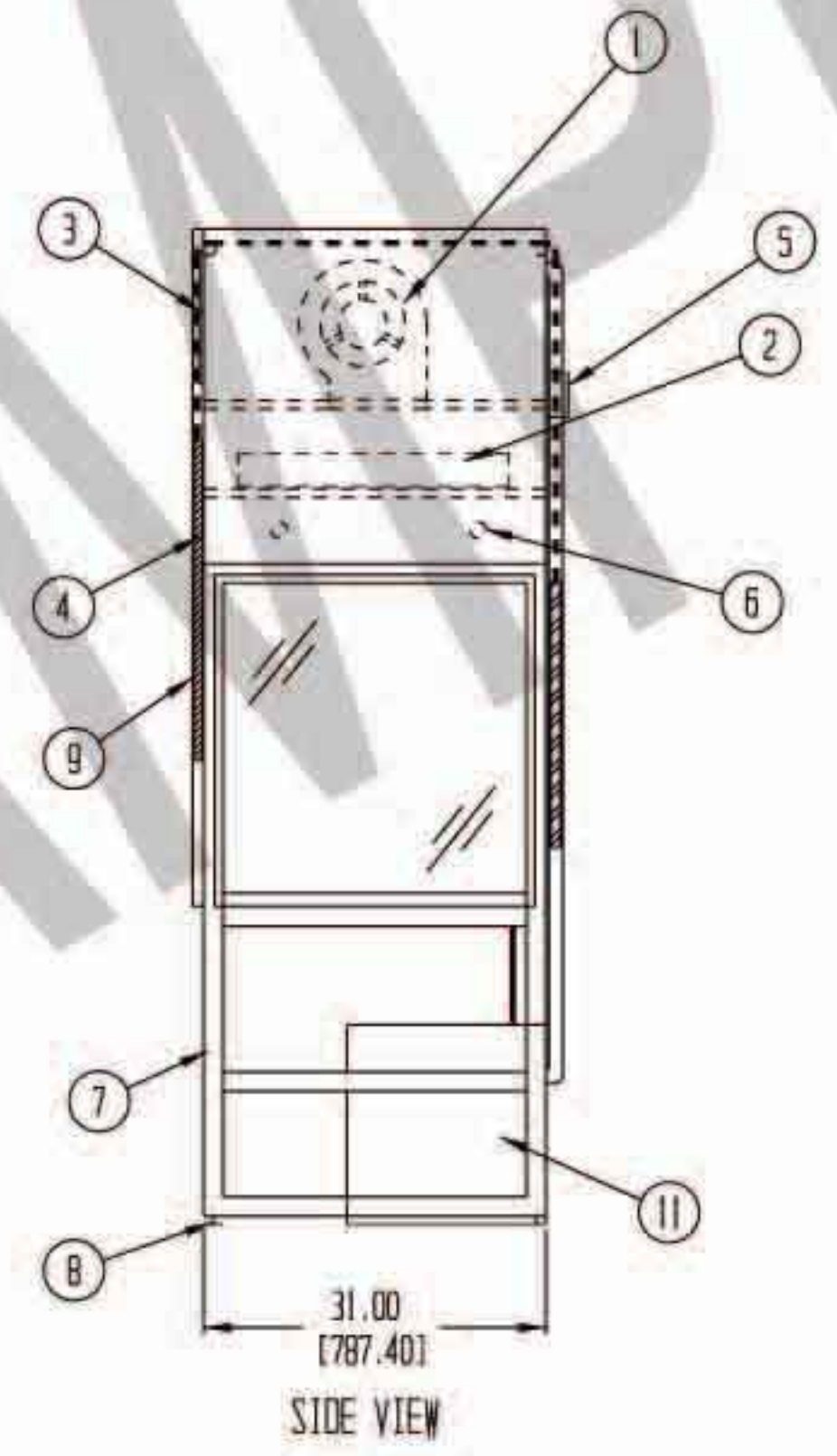
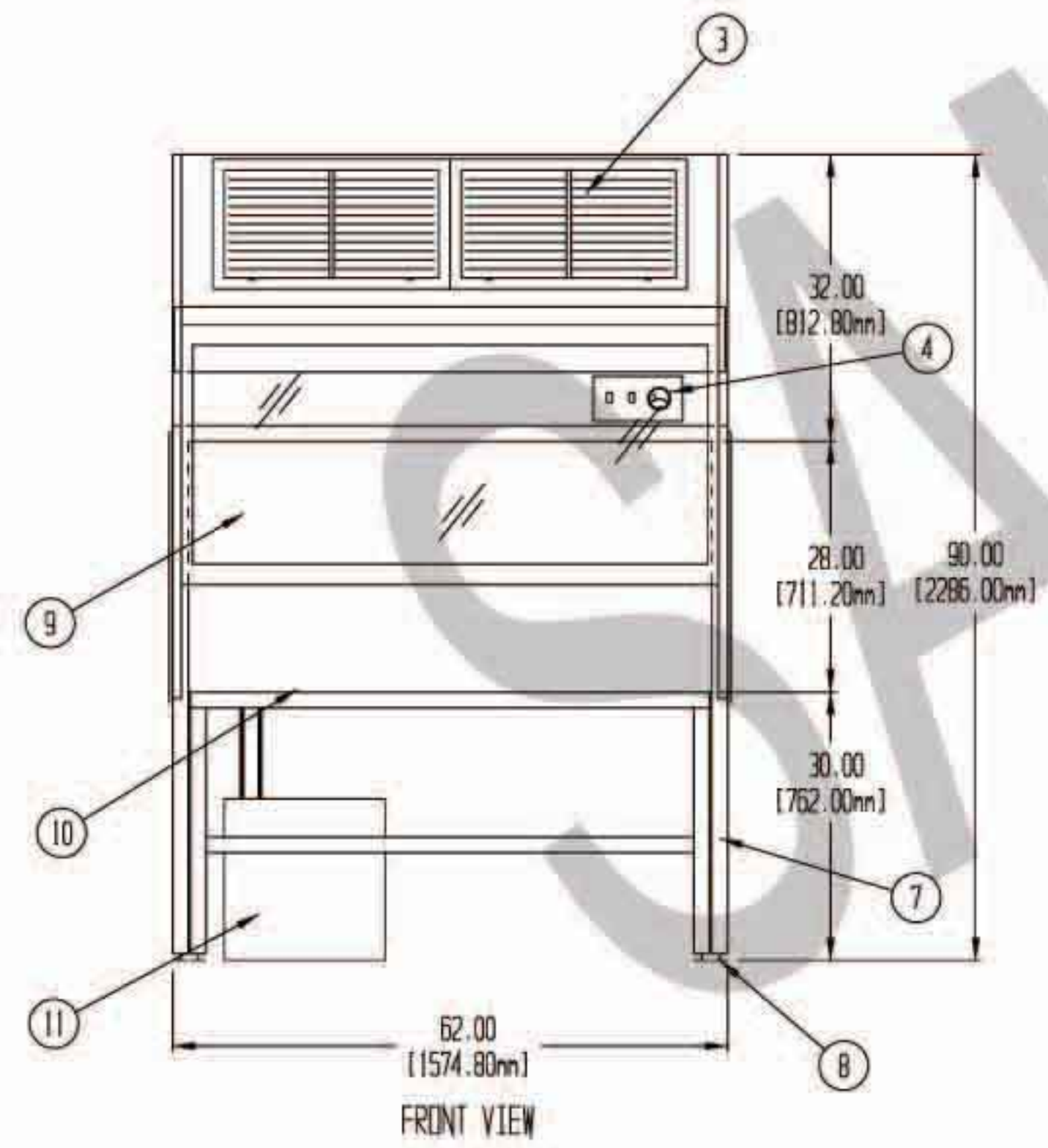

DRAWN BY		HALCO PRODUCTS COMPANY 100 NORTH GORDON STREET, ELK GROVE, IL 60007-1193		
TITLE		CAT5302-SFE/ST/SP (STAGE "C")		
APPROVED BY	OK	SIZE	JOB NO. 9356	ING. NO. 191032480
SCALE	1/2" = 1"	DATE	SHEET	